



RESERVOIR ROTERRA DRIVE

- ♻️ **Can be installed in road surfaces (load class C250)**
- ♻️ **Easy cleaning and maintenance of the reservoirs interior**
- ♻️ **Long product life and recyclability**
- ♻️ **Quick installation and easy on-site handling**
- ♻️ **Suitable for various applications**
- ♻️ **Adaptable to ground elevations**
- ♻️ **Option of additional equipment according to the project (suction hoses, filters, etc.)**
- ♻️ **Slovenian product**

Product description

RoDrive tanks are suitable for a variety of uses and applications. They can be used as fire water tanks, water retention tanks, water storage tanks and more.

They are characterised by excellent statics, allowing the tank to be installed in road surfaces up to load class C 250 or axle loads up to 25 t/m2.

Technical specifications

VOLUME [L]	Material	Load class	Dimensions [L x D x H] [mm]	Inlet/outlet pipe	Net weight
40.000 L	polyethylene [PE]	C 250	8.510 x 2.450 x 3.720 mm	By project	1000 kg

Reservoir installation

The RoDrive tank must be installed in accordance with the manufacturer's instructions, which are available on the QR code. For further information or to have a technical team present when the product is installed, please contact projekt@roto.si or visit www.rotoECO.eu.

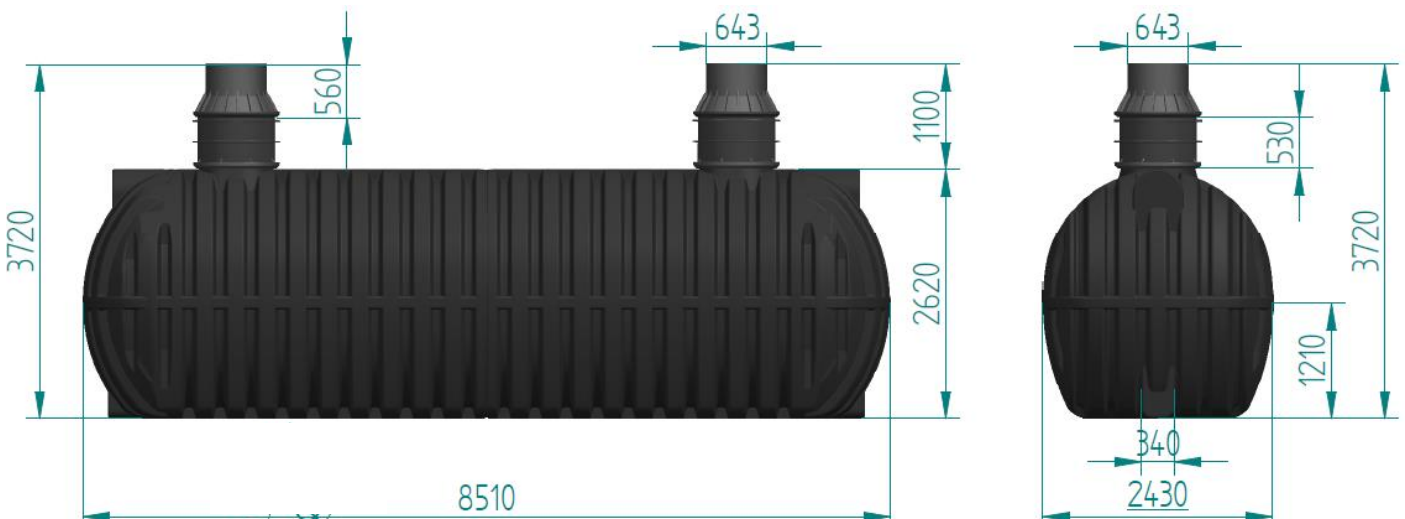

Rev. 2 / Feb 24

www.rotoECO.eu